

017

by Plagiarism Check

Submission date: 17-Mar-2023 10:44AM (UTC+0700)

Submission ID: 2039075885

File name: 017.pdf (1.6M)

Word count: 5505

Character count: 32257

International Journal of Psychosocial Rehabilitation

ISSN 1473-7192

Proudly Serving ear Web Based, International Readers Since 1996



**A WEB BASED PEER REVIEWED PUBLICATION FOR MENTAL
HEALTH PRACTITIONERS, CONSUMERS & APPLIED
RESEARCHERS**

www.psychosocial.com



Copyrights © 2020 SDA, LTD. All Rights Reserved.



International Journal of Psychosocial Rehabilitation

ISSN:1475-7192

[Login/Register \(/register-login\)](/register-login)

International Journal of Psychosocial Rehabilitation

ISSN 1475-7192

(Proudly Serving our Web Based, International Readers Since 1995)



A WEB BASED PEER REVIEWED PUBLICATION FOR MENTAL HEALTH PRACTITIONERS, CONSUMERS & APPLIED RESEARCHERS

www.psychosocial.com



Copyright © 2009-2020, IJPR. All Rights Reserved.

International Journal of Psychosocial Rehabilitation

ISSN : 1475-7192

Chief Editor Name : Dr. A.J. Anderson

Publisher Name : Hampstead Psychological Associates

Descriptions :

A WEB BASED PEER REVIEWED PUBLICATION FOR MENTAL HEALTH PRACTITIONERS, CONSUMERS & APPLIED RESEARCHERS

This private NON-PROFIT professional publication and associated web-based, information archive service is dedicated to the enhancement of practice, program development, program evaluation and innovations in mental health and substance abuse treatment programs worldwide. Its goal is to provide a public forum for practitioners, consumers and researchers to address the multiple service needs of patients and families and help determine what works, for whom under a variety of circumstances.

[Submit Online \(/submit-online\)](/submit-online)

For authors



International Journal of Psychosocial Rehabilitation

ISSN:1475-7192

[Login/Register \(/register-login\)](#)

Journal Information

This peer reviewed Journal was created in 1996 by practitioners, mental health program managers and mental health consumers to provide international practitioners, scholars and consumers with a forum to publish and discuss their work in program development, evaluation research, policy innovations, and therapeutic practices that have been successful in their particular region and cultures. IJPR is not associated with any university or governmental institution, nor is it part of any 'old boy' or other professional network. It was created to provide information to an international readership about issues related to psychosocial rehabilitation and associated topics.

Articles on psychosocial interventions, psychopharmacotherapy, mental health primary care, institutional and community care innovations, decentralization, policy changes, community & regionally based systems, and program evaluation are given particular attention. However, all articles that relate to psychosocial rehabilitation will be considered.

We invite comment from all readers on any and all subjects published in this journal, including the journal format itself. Feel free to comment on the Bulletin Board as well.

Current Editorial Board

A. Anderson, Ph.D. – United Kingdom

R. Eisenma, Ph.D. – United States

M. Melnichuk, Ph.D. – Ukraine

D Young, Ph.D. – Hong Kong

K. Yip, Ph.D. – Hong Kong

A. Johnston, R.N. – United Kingdom

J. Shankaar, Ph.D., RSW – Canada

B. Taylor – Australia

M. Hajri, MD – Tunisia

Dr. Nira Hariyatie Hartani – Malaysia

Asst. Prof. Dr. Mohd Armi Abu Samah – Malaysia

editor@psychosocial.com

Associate Editors

Dr. Haseeb Muhammad, Malaysia

Ass. Prof. Dr. I Wayan Suryasa, Indonesia

Publishing Information

The International Journal of Psychosocial Rehabilitation is published by ADG, S.A. (ADG) ADG is a private non-profit, limited corporation in Honduras and operating in a limited capacity in the United Kingdom. All information in IJPR is provided for personal use. Reproduction for publication or other use is strictly prohibited. Written permission must be obtained ADG, S.A., to reprint any information contained within the Journal, either in part or its entirety. Such permission may be requested in writing at the address listed below:

Dr. A.J. Anderson

Managing Editor – IJPR

Suite B19, 110 Gloucester Road,

London, NW1 8JA.

United Kingdom

submission@psychosocial.com

For authors

Scope (<https://www.psychosocial.com/scope/>)

Track Your Paper (<https://www.psychosocial.com/track-your-paper/>)

Submit Online (<https://www.psychosocial.com/submit-online/>)

Editorial Overview (<https://www.psychosocial.com/editorial-overview/>)

Instructions for Authors (<https://www.psychosocial.com/instructions-for-authors/>)

Privacy & Cookie Policy (<https://www.psychosocial.com/privacy-cookie-policy/>)

Terms & Conditions (<https://www.psychosocial.com/terms-conditions-of-use/>)

Quick Links

About Publisher (<https://www.psychosocial.com/about-publisher/>)

Copy Rights (<https://www.psychosocial.com/text-book/>)

Contact Us

editor@psychosocial.com (mailto:editor@psychosocial.com)

Hampstead Psychological Associates,

Suite B19, 110 Gloucester Road,

London, NW1 8JA.

United Kingdom

Copyrights © 2020 SDA, LTD. All Rights Reserved.

Issue 7

The relationship between self-esteem and intimate partner violence (IPV): The mediating role of resilience

Authors: Samina Ashraf Chaddher*, Roselisa Binti Ahmad

DOI: 10.37200/IJPR.V24I7.PR270001

Pages: 1-9

Keywords: Intimate partner violence, Domestic violence, Self-esteem, Resilience

[Abstract](#)

[Download](#)

THE EFFECT OF SUPERVISOR SUPPORT TO TURNOVER INTENTION MEDIATING BY COMPETENCE, PSYCHOLOGICAL EMPOWERMENT AND WORK ENGAGEMENT

Authors: Suprihati, Budiyanto, Suhermin

DOI: 10.37200/IJPR.V24I7.PR270971

Pages: 9683-9692

Keywords: Turnover intention, supervisor support, competence, psychological empowerment, work engagement

[Abstract](#)

[Download](#)

Quality of Life and Related Factors Among Hepatitis B Virus Infected Individuals

Authors: Muhammad Miftahussurur, Diah Priyantini, Isna Mahmudah, Ricky Indra Alfaray, Amie Vidyani, Maria Lucia Inge Lusida, Langgeng Agung Waskito, Yudith Annisa Ayu Rezkitha

DOI: 10.37200/IJPR.V24I7.PR270972

Pages: 9693-9699

Keywords: Quality of Life, Hepatitis B, Contributing Factors

[Abstract](#)

[Download](#)

Cyber-bullying among adolescent at school: A literature review

Authors: Le Ngoc Ai Nhung, Agus Basuki, Tuatul Mahfid, Ida Nugroho Saputro

DOI: 10.37200/IJPR.V24I7.PR270973

Pages: 9700-9712

Keywords: cyber-bullying, cyber-victimization, bullying, school adolescent, digital aggression,

[Abstract](#)

[Download](#)

Community Application of Agroforestry in Sigi District, Indonesia

Authors: Rafiuddin, Imran Rachman, Andi Sahri Alam, Rajindra, Ahmad Yani

DOI: 10.37200/IJPR.V24I7.PR270974

Pages: 9713-9719

Keywords: Agroforestry, Agroforestry Patterns, Organized Places, Permanent Random.

[Abstract](#)

[Download](#)

Current Status of Semiotic Use

Authors: Surapongse Sotanasathien

DOI: 10.37200/IJPR.V24I7.PR270975

Pages: 9720-9734

THE EFFECT OF SUPERVISOR SUPPORT TO TURNOVER INTENTION MEDIATING BY COMPETENCE, PSYCHOLOGICAL EMPOWERMENT AND WORK ENGAGEMENT

Suprihati,¹ Budiyanto,² Suhermin³

Abstract - Turnover intention is the intention of employees to ¹⁶ working from work voluntarily or move from one work place to another according to their own choice. This study aims to analyze the direct effect of supervisor support on turnover intention, and the indirect effect between competence, psychological empowerment and work involvement as a mediating variable on turnover intention. The research method is survey method in which primary data collection is obtained directly from textile industry employees and Central Java textile products. Non-random sampling technique with sampling ¹⁷ accidental sampling with research samples of 270 employees of the textile and textile product industries. Data were analyzed using the Structural Equation Modeling method with AMOS. The results of the data analysis show that competence, psychological empowerment and employee involvement have proven to be capable as mediators of turnover intention. This research has implications as material for evaluation and feedback on efforts to handle and improve employees, especially the handling of turnover intention in the textile industry and textile products.

Keywords: Turnover intention, supervisor support, competence, psychological empowerment, work engagement

1.1 Introduction

High turnover in the textile industry and textile products is important to be studied and sought a solution. This study was conducted to analyze the factors causing high employee turnover in the textile and textile product industries in Central Java, namely low salaries received by employees, wrong recruitment, and lack of career opportunities, poor management and disrespect for employee opinions.

Some factors that cause turnover intention include psychological empowerment, work involvement and supervisor support. Psychological empowerment is a psychological identification of a person to his work, active participation in work is considered as an important part for employees because it gives actualization space in their work.

In turnover intention research the writer uses is to choose four influencing variables, namely supervisor support, competence, psychological empowerment and work involvement. The consideration of selecting the four variables is based on the findings of previous studies which are still partial with reasons in accordance with the theme of human resource management.

¹ Student of Program Doctoral (STIESIA) Surabaya, Indonesia

² Sekolah Tinggi Ilmu Ekonomi Indonesia (STIESIA) Surabaya, Indonesia

³ Sekolah Tinggi Ilmu Ekonomi Indonesia (STIESIA) Surabaya, Indonesia

Table 1.1

5
Turnover of Textile Industry Employees and Textile Products in Central Java

Year	Number of Employees	Employees		Average Employee(%)	
		In	Out	In	Out
2014	30.560	3347	987	10,95	3,23
2015	29.656	2059	1457	6,94	4,91
2016	27.894	1678	2702	6,02	9,69
2017	23.672	2966	326	12,53	1,38
2018	58.318	12795	15014	21,94	25,75

Source: Employment BPJS of Central Java, 2018

States that many factors can affect the company's turnover intention on employees, including organizational commitment, employee performance, work stress, career development, psychological empowerment, job satisfaction, competence and low employee involvement. The employee involvement factor is psychological identification of a person in his work, active participation and work is considered as an important part of an individual's life. While the problems faced by the company today are low work involvement among employees which results in high turnover intention for employees. (Proninet *et al*, 2018)

According to Berry and Morris (2008) that there are several factors that influence the occurrence of turnover intention, including external factors, namely the labor market, institutional factors namely workspace conditions, 3 ages, work skills, and supervision, personal characteristics of employees such as intelligence, attitude, time then, sex, interests, age and length of work and individual reactions to their work. 11

Kalidass and Bahron, (2015); Dawley *et al*, (2008) states that high turnover intention is influenced by supervisor support, organizational support, organizational commitment, and mentoring, through his research proving the positive influence between supervisor support and turnover intention. In accordance with the opinion of De Cuyper *et al*, (2011) states that the high turnover intention is influenced by supervisor support, organizational support and organizational commitment.

Zahra and Khalid, (2016); De Klerk and Stander, (2014) States that turnover intention is influenced by psychological empowerment, work involvement, leadership empowerment, employee work attitudes and organizational learning. Dysvik and Kuvaas, (2013) State that there is a significant negative effect between psychological empowerment on turnover intention. According Bilal (2013: 25) states that the factors that influence turnover intention are psychological empowerment, organizational commitment and organizational behavior.

Jones and Harter, (2005) State that turnover intentions are influenced by factors of employee involvement, career development, supervisor support, employability and organizational resources. Factors affecting turnover intention are employee involvement, organizational commitment and organizational behavior attitudes. This means that the higher the involvement of employees / employees in the company, the lower the turnover intention, and vice versa (Nancarrow, *at al*, 2014).

2.1 Theoretical Review

Theory of Planned Behavior (TPB) seems very suitable to explain turnover intentions; in this case the actions taken are based on a very complex psychological process (Wong, 2015). Theory of Planned Behavior (TPB) is a development of Theory of Reasoned Action (TRA), Berry and Morris, (2008) Furthermore Ajzen's said TPB has been widely accepted as a tool to analyze the difference between attitudes and intentions as well as intentions and behaviors. In this case, efforts to use TPB as an approach to explain turnover intentions can help overcome some of the limitations of previous research and provide a means to understand the widely observed gaps between attitudes and behavior (Dawley *et al*, 2008).

1. Intention Turnover

Turnover intention is the tendency or level at which an employee has the desire to leave the company or leave. Researchers measure turnover intention indications referring to the opinions of Aguirre, (2015) as quoted in (Van Schalkwyk, 2010). Indicators used to determine turnover include: thoughts of leaving, a desire to leave the

organization in the near future and a desire to look for other job openings. Thinking you don't have a good future if you keep working in this company.

2. Supervisor Support

Supervisor support is the extent to which leaders value the contribution of their employees and care about their well-being and are responsible for monitoring employee performance, conducting periodic assessments, and providing feedback to increase employee contributions and commitment to the organization, indicating supervisor support refers to opinions Roslee and Effendi, (2016) indicators used to determine supervisor support include: willingness to provide assistance, willingness to listen and a feeling of caring.

3. Competence

(Abbasi, 2018) Competence is the capacity that exists in someone who can make that person able to fulfill what is required by work in an organization so that the organization is able to achieve the expected results. The ability of an employee to be able to carry out their work well, technical or functional competence or can also be called hard skills / hard competency and behavioral competencies or can also be called soft skills / soft competencies, an indication of competency refers to opinions (Schalkwyk, 2010). Indicators used to determine competence include: cognitive abilities, individual abilities, resource capabilities, interpersonal skills and information and technology capability.

2.2 Psychological Empowerment

Psychological empowerment is defined as a set of psychological states that focus on how employees think and feel their work (Bester, 2015); (Widjaja, 2012). Psychological empowerment is a psychological state that focuses on how employees think about their work and to gain experience, and how much they believe in the role and influence of their organization, and can make employees feel more confident and have the will to succeed. Researchers measure indications of psychological empowerment based on opinions (Rahman and Ramli, 2013). Indicators used to determine psychological empowerment include: Meaningfulness, the meaning of the work's role, beliefs, values and behavior. Self-determination, feeling has the right to choose and determine. Competence means one's confidence in his ability to complete tasks. And Impact, the feeling of ability possessed in considering the influence of strategy, administration and operational risks that exist in the organization.

5. Work Engagement

Shankar and Bhatnagar, (2010) Work engagement is interpreted as a measure to the importance of the level of performance achieved as self-esteem. Work involvement has consequences in the form of work results including performance. Therefore, by becoming more involved in their work, employees are expected to be able to produce better performance because individuals with a high level of involvement in their work will see that their work is an important part of their lives. Employee work involvement is an active participation of an employee in completing his work and shows willingness and desire to be directly involved in work. The researcher measures the indication of employee involvement referring to opinions (Amah and Ahiauzu, 2010). Indicators used to determine employee work engagement include: employee engagement with colleagues, employee involvement with customers or customers, employee involvement with leaders or superiors, work involvement with work time. Based on empirical and theoretical studies, the conceptual framework in this study is structured as follows:

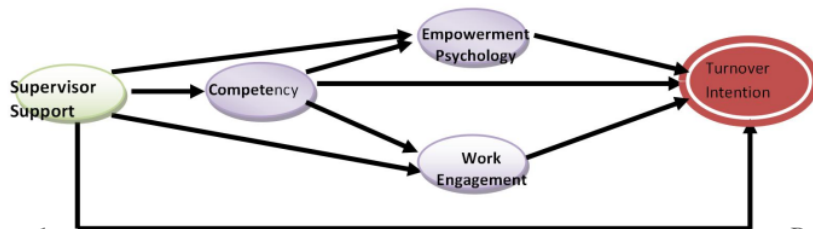

Figure 1

Researches

Conceptual Framework

3.1 Hypothesis

- H1: Supervisor support has a significant and positive effect on turnover intention.
 H2: Competence significantly mediates the effect of supervisor support on turnover intention.
 H3: Psychological empowerment significantly mediates the effect of supervisor support on turnover intention.

- H4: Work engagement significantly mediates the effect of supervisor support on turnover intention.
- H5: Psychological empowerment significantly mediates the effect of competence on turnover intention.
- H6: Work engagement mediates the effect of competence on turnover intention.

4.1 Research Method

This research is using a descriptive approach with the aim to describe the empirical conditions of the management of turnover intention in the textile industry and textile products in Central Java, in order to obtain a picture of the state of turnover intention in accordance with the objectives of this study. Inferential statistical methods in this study are used to analyze the behavior of turnover intention data on supervisor support, competence, and psychological empowerment and work involvement, so that patterns are found that can be used to determine human resource management models in the textile and textile product industries, samples obtained 5 x 54 or 270 samples. respondents with a sample reason of 270 respondents can represent the population of the textile industry and textile products in Central Java. Sampling in each of the textile industry and textile products in Central Java using proportional namely ni

$$= \frac{x_i}{\sum x_i} \times n$$

Information,

ni = sample for each textile industry and textile products

xi = number of employees in each textile and textile product industry

$\sum x_i$ = total population

n = total research sample

The non-probability sampling method by using accidental sampling or convenience sampling. To test the hypothesis in this study using structural equation modeling (SEM) analysis with AMOS version 22, Confirmatory Factor Analysis (CFA) and sobel test.

5.1 Experiment And Result

5.2 SEM Evaluation Result

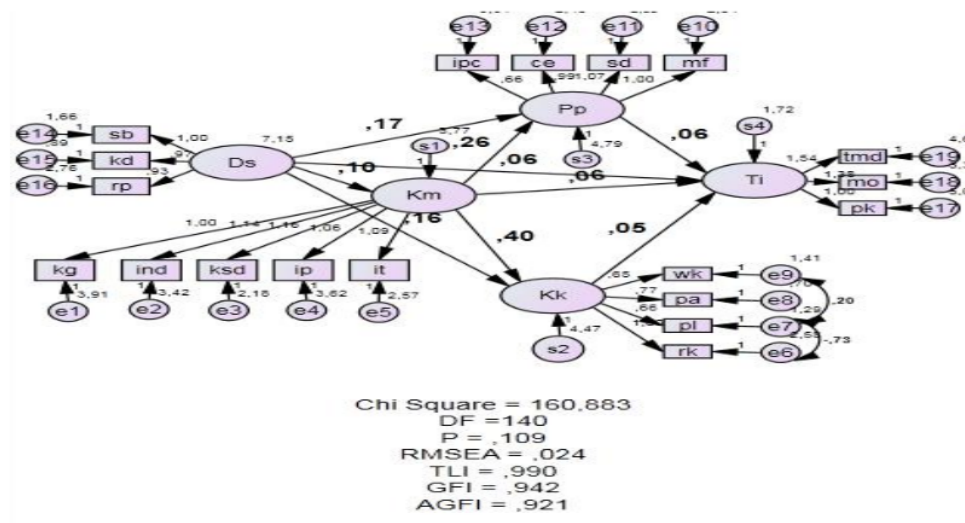

Figure2. Model two-step approach Modification to SEM

1. Outlier Test

Table 5.1
Mahalanobis Distance Calculation Results

Observation number	Mahalanobis d-squared	p1	p2
173	41,844	0,002	0,395
244	36,219	0,01	0,749
40	34,787	0,015	0,764
163	34,396	0,016	0,652
52	34,297	0,017	0,483
241	34,103	0,018	0,353
.	.	.	.
.	.	.	.

2. Normality Test

Table 5.2

Assessment of Normality

Variabel	min	max	skew	c.r.	kurtosis	c.r.
Tmd	3	15	-0,447	-2,999	-0,861	-2,388
Mo	3	15	-0,523	-3,505	-0,438	-1,469
Pk	3	15	-0,213	-1,426	-0,543	-1,82
Rp	5	15	-0,015	-0,099	-1,321	-2,431
Kd	3	15	-0,265	-1,78	-0,846	-2,837
Sb	3	15	-0,479	-3,216	-0,618	-2,072
Ipc	6	15	-0,065	-0,437	-1,23	-2,127
Ce	4	15	-0,463	-3,107	-0,892	-2,993
Sd	4	15	-0,08	-0,537	-1,058	-2,55
Mf	5	15	-0,017	-0,114	-1,048	-2,515
Wk	3	10	-0,32	-2,148	-0,952	-2,194
Pa	3	10	-0,318	-2,13	-0,998	-2,349
Pl	2	10	-0,26	-1,745	-0,788	-2,642
Rk	5	15	0,144	0,968	-1,104	-2,704
It	5	15	-0,384	-2,575	-0,94	-2,154
Ip	4	15	-0,169	-1,137	-0,887	-2,977
Ksd	4	15	-0,194	-1,304	-0,812	-2,724
Ind	4	15	-0,093	-0,627	-1,113	-2,732
Kg	3	15	-0,092	-0,619	-0,916	-2,073
Multivariate					2,035	2,046

3. Multicollinearity Test

Table 5.3.

Condition Number Calculation Result

Condition number = 52,286
Eigenvalues
37,352 20,630 17,285 13,242 10,560 6,318 4,833 4,002 3,890 3,547 3,077
2,669 2,443 2,182 2,016 1,747 1,257 ,958 ,714
Determinant of sample covariance matrix = 416363340956,465

29
4. Goodness of Fit Indices Modification Criteria Evaluation

Table 5.4

13
Goodness of Fit

Goodness of fit indices	Result	Cut-off value	Model Evaluation
χ^2 (Chi-Square)	160,883	$\leq \chi^2_{(0,05; 140)} = 168,613$	Good
Significant Probability	0,109	$\geq 0,05$	Good
CMIN/DF	1,149	$\leq 2,00$	Good
RMSEA	0,024	$\leq 0,08$	Good
GFI	0,942	$\geq 0,90$	Good
AGFI	0,921	$\geq 0,90$	Good
CFI	0,992	$\geq 0,95$	Good
TLI	0,99	$\geq 0,95$	Good

5. Hypothesis Testing

Table 5.5
Significance of Path Analysis Test

Significance of the path coefficient	C.R Value	Value (P)	Test Result
Effect of DS and IT	2,442	0,015	Significant
Effect of DS and KM	9,455	0,000	Significant
Effect of DS and PP	2,985	0,003	Significant
Effect of DS and KK	3,040	0,002	Significant
Effect of KM and TI	2,107	0,031	Significant
Effect of KM and PP	3,139	0,002	Significant
Effect of KM and KK	4,915	0,000	Significant
Effect of PP and TI	2,762	0,012	Significant
Effect of KK and TI	3,133	0,002	Significant

6.1 Discussion

1. Effect of Supervisor Support on Turnover Intention

By coefficient of 0.058 and C.R Value $2.442 > 1.96$ (sig $0.015 < 0.05$). These results provide information that supervisor support has an acceptable turnover intention, so supervisor support has an influence on turnover intention in the textile industry and textile products in Central Java, because there is a positive correlation between supervisor supports has an effect on turnover intention.

2. Competence Mediates the Effect of Supervisor Support on Turnover Intention

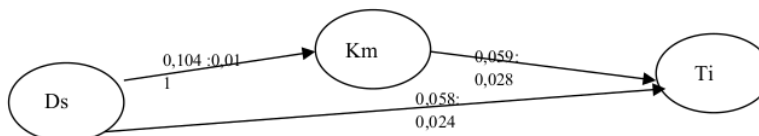

Figure 6.1. Path analysis Support for Supervision, Competency, Turnover Intention

$$Z = \frac{0,104 \times 0,059}{\sqrt{(0,059^2 \times 0,011^2) + (0,104^2 \times 0,028^2)}} = 2,057$$

Hypothesis 2 which states that competence mediates supervisor support for turnover intention is acceptable. The Sobel test value of 2.057 > cut-off 1.97 with a significant level <0.05 so competence decisively acts as a mediating variable that links the influence of supervisor support to turnover intention. So competence strengthens the influence of supervisor support on turnover intention, means that the interaction between supervisor support and competence will reduce employee desires to leave even lower. So the competence of one that is demanded in the textile industry and textile product companies, the effect is with turnover intention if the competency is not in accordance with their fields, it affects high turnover intention.

3. Psychological Empowerment Mediates the Effect of Supervisor Support on Turnover Intention

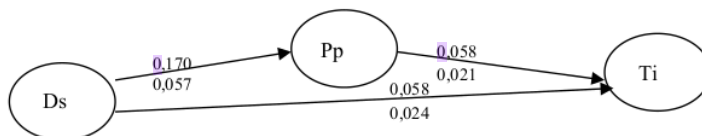

Figure 4. Path Analysis Supervisor Support, Psychological Empowerment, Turnover Intention

$$Z = \frac{0,170 \times 0,058}{\sqrt{(0,058^2 \times 0,057^2) + (0,170^2 \times 0,021^2)}} = 2,026$$

Hypothesis 3 which mentions psychological empowerment mediates supervisor support for the turnover intention of the textile and textile product industries in Central Java. Sobel test value 2.026 > cut-off 1.97 then psychological empowerment convincingly acts as a mediating variable that connects the influence of supervisor support to turnover intention. Psychological empowerment strengthens the influence of supervisor support on turnover intention, meaning that the interaction between supervisor support and psychological empowerment will reduce the desire of employees to leave the lower.

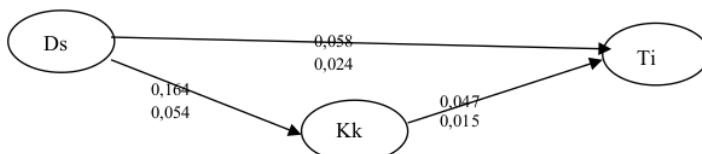

Figure 6.2 Path analysis Support for Supervision, Work Engagement, Turnover Intention

$$Z = \frac{0,058 \times 0,164}{\sqrt{(0,164^2 \times 0,024^2) + (0,058^2 \times 0,054^2)}} = 2,181$$

In this research based on the sobel test, there is an indirect effect between the variables studied, because the value of the sobel test is 2.18 > 1.96, it can be concluded that the work involvement variable is a mediator variable, in other words the supervisor's support is not necessarily directly influences the intention to change work but through work involvement as a mediator variable. Thus, the results of this study also prove the hypothesis that there is an influence between supervisor support and turnover intention through the mediator variable of work involvement in textile and product industry employees. Work engagement strengthens the influence of supervisor support on turnover intention, meaning that the interaction between supervisor support and work involvement will reduce employee desires to leave even lower.

4. Psychological Empowerment Mediates the Effect of Competence on Turnover Intention

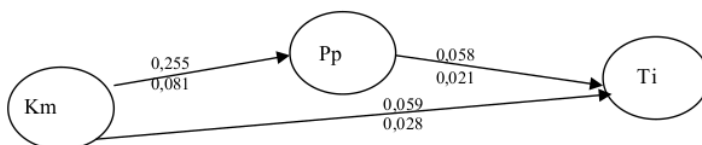

Figure 6.3 Path analysis Competency, Psychological Empowerment, Turnover Intention

$$Z = \frac{0,255 \times 0,058}{\sqrt{(0,058^2 \times 0,081^2) + (0,255^2 \times 0,021^2)}} = 2,076$$

This study of competency and intention to change job variables shows that competency has a significant influence on intention to change job which is indicated by the value of the sobel test $2.08 > 1.96$ that the psychological empowerment variable is a mediator variable, in other words, competence does not necessarily correlate directly with intention to change job but rather through psychological empowerment as a mediator variable. Psychological empowerment strengthens the influence of competence on turnover intention, it means that the interaction between competence and psychological empowerment will reduce employee desires to come out even lower. Because the aspects of meaningfulness, self-determination, Competence, and impact, it is necessary to get attention for management engaged in the TPT industry to pay attention to psychological empowerment of employees. Psychological empowerment when interacted with employees' internal abilities in the form of cognitive abilities, individual abilities, resource capabilities, interpersonal abilities and information and technology capabilities will provide a strong push or effect on employees' desire to stay at home not leaving the company.

5. Work Engagement Mediates the Effect of Competence on Turnover Intention

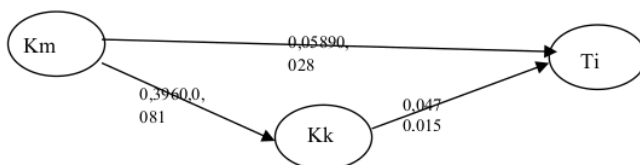

Figure 6.4. Path analysis Competency, Work Engagement, Turnover Intention

$$Z = \frac{0,104 \times 0,059}{\sqrt{(0,059^2 \times 0,011^2) + (0,104^2 \times 0,028^2)}} = 2,057$$

The work involvement mediates the effect of competence support on turnover intention in the textile and textile product industries in Central Java, can be accepted, because the results of test conducted in this study of the variables of competence and intention to move work indicate that competence has a significant influence on the intention to change work through work involvement, based on the sobel test $2.057 > 1.96$ that the variable work involvement is a mediator variable, in other words, competence does not directly influence the intention to change work but through work involvement as a mediating variable. Thus, the results of this study also prove hypothesis that there is an influence between competence on the intention to change job through mediating variables of work involvement in textile industry and textile product employees, mediating work involvement which strengthens the effect of competence on turnover intention can strengthen the effect of competence on turnover intention, it is necessary to get attention for management engaged in the textile industry to pay attention to employee work involvement. Work engagement includes employee involvement with colleagues, employee involvement with outside parties, employee involvement with the leadership or supervisor, employee involvement in working time combined with internal employee capabilities in the form of cognitive abilities, individual abilities, resource capabilities, interpersonal skills and information skills and technology will provide a strong impetus or effect on employees' desire to stay at home not to leave the company.

7.1 Conclusion

1. The results of statistical testing the effect of supervisor support on turnover intention proved significant. This means that the more intensive supervisory support is carried out by the textile industry and textile products, the more it can reduce the level of turnover intention. The results of this study provide a positive confirmation of the results of previous studies and give an indication of the importance of supervisor support that must be carried out by the textile industry and textile products.

2. The results of statistical tests prove that competence significantly mediates the effect of supervisor support on turnover intention. Competence strengthens the influence of supervisor support on turnover intention, meaning that the interaction between supervisor support and competence will reduce employee desire to leave even lower.
3. The results of statistical tests prove that psychological empowerment significantly mediates the effect of supervisor support on turnover intention. Psychological empowerment strengthens the influence of supervisor support on turnover intention, meaning that the interaction between supervisor support and psychological empowerment will reduce the employee's desire to leave the lower.
4. The results of statistical tests prove that work involvement significantly mediates the effect of supervisor support on turnover intention. work involvement strengthens the influence between supervisor support on turnover intention, meaning that the interaction between supervisor support and work involvement will reduce employee desires to leave even lower.
5. The results of statistical tests prove that psychological empowerment significantly mediates the effect of competence on turnover intention. Psychological empowerment strengthens the influence of competence on turnover intention, meaning that the interaction between competence and psychological empowerment will reduce employee desires to come out even lower.
6. The results of statistical tests prove that work involvement significantly mediates the effect of competence on turnover intention. work engagement strengthens the influence between competencies on turnover intention, meaning that the interaction between competencies and work involvement will reduce employee desires to leave the lower.

REFERENCES

- Aguirre , L. R. D., Roncancio, P. R Aranda, M. M.,& Campos, Á. F. R. (2015). Instrument for Measuring Intentions to Leave, *Asia-Pacific Journal Management. Resources. Innovation.* 11(4), 313–322.
- Amah. E., & Ahiauzu, A. (2013). Employee involvement and organizational effectiveness, *Journal Management Division.* 32 (7),661–674,
- Berry.M. L., & Morris,M. (2008). The Impact of Employee Engagement Factors and Job Satisfaction on Turnover Intention,," Online Submiss.,
- Bester, J. M. W. Stander., & Van Zyl, L. E. (2015) "Leadership empowering behaviour, psychological empowerment, organisational citizenship behaviours and turnover intention in a Manufacturing Division, *Journal. Ind. Psychological.* 41(1), 102- 115.
- Dawley, D. D, Andrews, M. C. , & Bucklew, N. S. (2008). Mentoring, supervisor support, and perceived organizational support: What matters most, *Leadersh. Organization Division Journal.* 29 (3), 235–247.
- De Cuyper.N., Mauno, S., Kinnunen, U ., & Mäkikangas, A. (2011) The role of job resources in the relation between perceived employability and turnover intention: A prospective two-sample study, *Journal Vocation Behavior.* 78 (2), 253–263.
- DeKlerk, S., & Stander, M.W. (2014). Leadership Empowerment Behaviour, Work Engagement and Turnover Intention: the Role of Psychological Empowerment. *Journal of Positive Management*5(3), 28-39.
- Dysvik, A. dan Kuvaas, B.(2013). Perceived job autonomy and turnover intention: The moderating role of perceived supervisor support. *European Journal of Work and Organizational Psychology*22(5)., 563–573.
- Jones, J. R., & Harter,J.K. (2005). Race Effects on the Employee Engagement-Turnover Intention Relationship. *Journal of Leadership & Organizational Studies*11(2) ,78–88.
- Kalidass, A& Bahron. A. (2015). The Relationship between Perceived Supervisor Support, Perceived Organizational Support, Organizational Commitment and Employee Turnover Intention. *International Journal of Business Administration*6(5), 82 -89.

- Nancarrow, S, Bradbury, J.J. Pit, J., & Ariss, S. (2014). Intention to stay and intention to leave: Are they two sides of the same coin? A cross-sectional structural equation modelling study among health and social care workers, *Journal. Occup. Health.*, 56 (4), 292–300.
- Pronin, E, Jacobs, E., & Wegner, D.M. (2008). Psychological Effects of Thought Acceleration, *Emotion*, 8 (5), 597–612,
- Rahman, A., & Ramli, R. (2013). Average concept of crossover operator in real coded genetic algorithm, *Int. Proc. Econ. Dev. Res.* 63(15), 73–77.
- Roslee, A., & Effendi, A.A. (2016). Retaining Quality Employees through Career Development and Perceived Supervisor Support. In 3rd. *International Conference On Gender Studies*: 391–401.
- Shankar, T & Bhatnagar, J. (2010). Work Life Balance, Employee Engagement, Emotional Consonance/dissonance and Turnover Intention,” *Indian Journal. Ind. Relat.* 46(1), 74
- Tayebe Abbasi, Gholamreza Taleghani, & Somayye Rajabzade. (2016). Psychological Empowerment and public services innovation; with emphasise employee engagement, *Journal Public Adm.* 7 (4), 743–764.
- Van Schalkwyk S, Du Toit, D. H, Bothma, A. S., & Rothmann, S. (2010). Job insecurity, leadership empowerment behaviour, employee engagement and intention to leave in a petrochemical laboratory,” *SA Journal. Human. Resources. Managemen.* 8 (1), 1–7.
- Wong, Y. J. (2015). The Psychology of Encouragement: Theory, Research, and Applications,” *Couns. Psychol.* 43(2), 178–216.
- Widjaja, D. C, Fulbertus, M., & Kusuma D.W. (2012). Analisis Persepsi Employee Empowerment Terhadap Employee Turnover Intention Di Hotel X, Kupang, Nusa Tenggara. *Journal. Manajemen. Perhotelan*, 4(2) , 72-84.
- Zahra . S, Malik & Khalid, N. (2016). Psychological contract breach, work engagement and turnover intention: Evidence from Banking Industry in Pakistan, *Pak. Econ. Soc. Rev.*, 54(1), 37–54.



Loading comments...

Developed by:



Powered by:



Follow us on @ScimagoJR

Scimago Lab, Copyright 2007-2020. Data Source: Scopus®

EST MODUS IN REBUS

Horatio (Satire 1.1.106)



Start Advertising on YouTube

Engage with your most valuable audiences on the world's largest video platform.

YouTube Advertising

OPEN

International Journal of Psychosocial Rehabilitation

Country [United Kingdom](#) - [SJR Ranking of United Kingdom](#)

7

Subject Area and Category [Medicine](#)
[Psychiatry and Mental Health](#)

[Nursing](#)
[Psychiatric Mental Health](#)

[Psychology](#)
[Clinical Psychology](#)

H Index

Publisher [Hampstead Psychological Associates](#)

Publication type Journals

ISSN 14757192

Coverage 2009-2011, 2013-2020

Scope Information not localized

[Join the conversation about this journal](#)



2020 call for papers

Peer Reviewed Journal, Indexed, Fast.

[asrjetsjournal.org](#)

OPEN

Quartiles

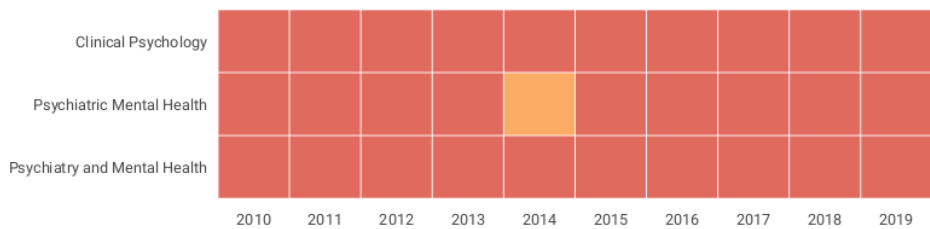

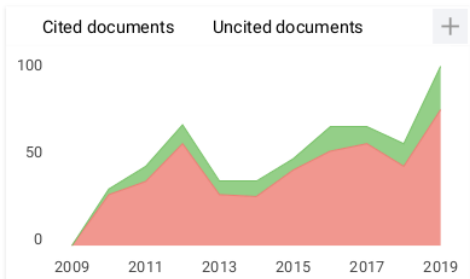
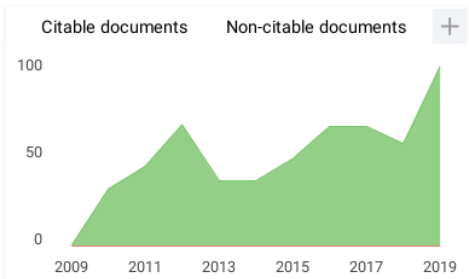
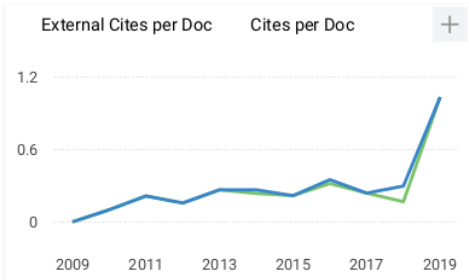
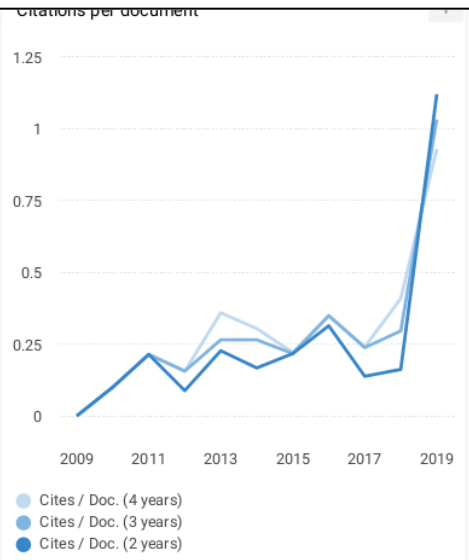
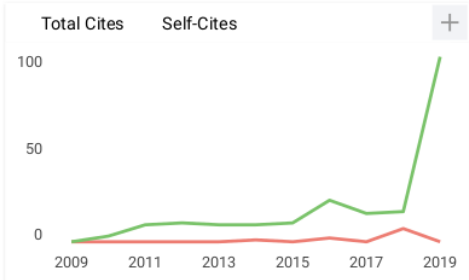
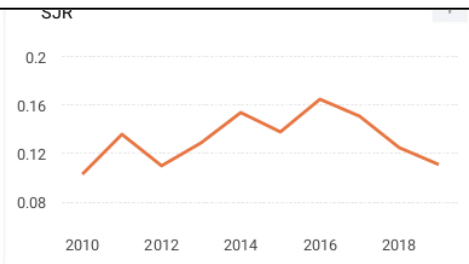

International Journal of Psychosocial Rehabilitation

← Show this widget in your own website

Q4 Clinical Psychology
best quartile

SJR 2019 0.11

powered by scimagojr.com

Just copy the code below and paste within your html code:

```
<a href="https://www.scimagojr.com">
```

Instant Grammar Checker

Trusted by millions of students, faculty, and professionals worldwide. Try now

Grammarly DOWNLOAD

ORIGINALITY REPORT

14%

SIMILARITY INDEX

12%

INTERNET SOURCES

8%

PUBLICATIONS

%

STUDENT PAPERS

PRIMARY SOURCES

1	ejournal.poltekkes-smg.ac.id Internet Source	2%
2	repository.iainponorogo.ac.id Internet Source	1%
3	www.ca-c.org Internet Source	1%
4	Dona Primasari, Lego Wasapodo, Muhammad Thareq Ilhami. "The Influence of Attitudes, Perception of Control and Internal Control System on Whistleblowing Intention with Legal Protection as a Moderation Variable (study on PT Kereta API Indonesia) title", <i>Buhalterinés apskaitos teorija ir praktika</i> , 2022 Publication	1%
5	publishing-widyagama.ac.id Internet Source	1%
6	www.ijstr.org Internet Source	1%
7	publikasiilmiah.unwahas.ac.id Internet Source	1%

8	<p>Mohammad Rachman Waluyo, Nurfajriah, Haris Adi Swantoro, Evan Filbert, Pinta Imanda. "Construction of Collaboration Model of Supply Chain Management on Business Performance and Sustainable Competitive Advantage Using Structural Equation Modeling (SEM) Method", Journal of Physics: Conference Series, 2020</p> <p>Publication</p>	1 %
9	<p>dergipark.org.tr</p> <p>Internet Source</p>	1 %
10	<p>www.ncbi.nlm.nih.gov</p> <p>Internet Source</p>	1 %
11	<p>Asmaa Khaled Abd El-Aziz, Rabab Mahmoud Hassan, Fawzia Farouk Kamel. "Perceived Nursing Supervisor Support and its Relation to Turnover Intention among Staff Nurses", Egyptian Journal of Health Care, 2017</p> <p>Publication</p>	<1 %
12	<p>scholarworks.sjsu.edu</p> <p>Internet Source</p>	<1 %
13	<p>Ratnawati Susanto, Reza Rachmadtullah, Widarto Rachbini. "Technological and Pedagogical Models: Analysis of Factors and Measurement of Learning Outcomes in Education", Journal of Ethnic and Cultural Studies, 2020</p> <p>Publication</p>	<1 %

14

N W Sukartini, N M Sudarmini, N K Lasmini. "Relationship between human resource ability and market access capacity on business performance. (case study of wood craft micro- and small-scale industries in Gianyar Regency, Bali)", Journal of Physics: Conference Series, 2018

Publication

<1 %

15

ULUTAŞ, Mehmet. "PERSONEL GÜÇLENDİRMENİN İŞGÖRENLERİN İŞTEN AYRILMA EĞİLİMİ ÜZERİNE ETKİSİ: KONYA SANAYİ BÖLGESİ ÜZERİNE BİR UYGULAMA", Erzincan Üniv. Fen Edebiyat Fak. Türk Dili ve Edebiyatı Bl., 2017.

Publication

<1 %

16

Aamar Ilyas, Ahmed Hussain Khan, Farah Zaid, Muhammad Ali, Asad Razzaq, Waris Ali Khan. "Turnover Intention of Employees, Supervisor Support, and Open Innovation: The Role of Illegitimate Tasks", Journal of Open Innovation: Technology, Market, and Complexity, 2020

Publication

<1 %

17

app.trdizin.gov.tr

Internet Source

<1 %

18

rjoas.com

Internet Source

<1 %

19	www.iosrjournals.org Internet Source	<1 %
20	ajoeijournals.org Internet Source	<1 %
21	Hafidz Risqiadi Putra, Sfenrianto -. "Analysis of Customer Satisfaction Factors on e-Commerce Payment System Methods in Indonesia", International Journal of Advanced Computer Science and Applications, 2020 Publication	<1 %
22	core.ac.uk Internet Source	<1 %
23	digibug.ugr.es Internet Source	<1 %
24	journal.uta45jakarta.ac.id Internet Source	<1 %
25	rportal.lib.ntnu.edu.tw:8080 Internet Source	<1 %
26	scholarworks.waldenu.edu Internet Source	<1 %
27	Marita M. Heyns, Sean McCallaghan, Elizabeth H. de Wet. "The role of supervisor support and basic psychological needs in predicting work engagement, burnout and turnover intentions in a medical contract research	<1 %

service setting", Research in Social and Administrative Pharmacy, 2021

Publication

28

trijurnal.lemlit.trisakti.ac.id

Internet Source

<1 %

29

Andra Charis MIJARES, Mio SUZUKI, Tetsuo YAI. "An Analysis of Metro Manila MRT-3 Passengers' Perceptions of Their Commuting Experience and its Effects Using Structural Equation Modeling", Asian Transport Studies, 2016

Publication

<1 %

Exclude quotes On

Exclude matches Off

Exclude bibliography On